

## Application

The EFD-637-MD is engineered and tested to withstand extreme loads, debris impact and cyclic fatigue failure associated with the severe weather effects of hurricanes (Miami-Dade County approval #09-0212.08). Constructed from 6063-T5 extruded aluminum the EFD-637-MD's unique load-bearing design accommodates installations of unlimited length and single section assemblies up to 48" × 144" (1219 × 3658) without adding costly intermediate structural supports required by other products. Specially designed water resistant seam covers further enhance performance and aesthetics of this industry leading product.

## Standard Construction

**Material:** Mill finish 6063-T5 extruded aluminum.

**Frame:** 6" deep × 0.125" thick (152 × 3) channel.

**Blades:** 37½° × 0.081" (2) thick horizontal style.

**Screen:** ½" × 0.063" (12.7 × 1.6) expanded and flattened aluminum.

**Mullion:** Visible.

**Minimum Size:** 4.5" × 8" (114 × 203)

**Maximum Size:** Single section: 48" × 144" (1219 × 3658)  
Multiple section: Unlimited width × 144" (3658)

## Options

- Factory finish:
  - High Performance Fluoropolymer - 100% resin Newlar®/ 70% resin Kynar®
  - Baked Enamel
  - Clear or Color Anodized, Class 1
  - Prime Coat
- 1½" (38) flange frame.
- Heavy duty 0.125" (3) construction.
- Alternate bird or insect screens.
- Insulated or non-insulated blank-off panels.
- Filter racks.
- Head and/or sill flashing.

## Ratings

**Free Area:** [48" × 48" (1222 × 1222) unit]: 9.5 ft<sup>2</sup> (0.88 m<sup>2</sup>)  
59.4%

### Performance @ Beginning Point of Water Penetration

**Free Area Velocity:** 990 fpm (5.03 m/s)  
**Air Volume Delivered:** 9,405 cfm (4.44 m<sup>3</sup>/s)  
**Pressure Loss:** 0.11 in.wg. (27 Pa)

**Velocity @ 0.15 in.wg. Pressure Loss:** 1150 fpm (5.84 m/s)

**Miami Dade County:** NOA No. 09-0212.08  
Approved to protocol PA201, PA202,  
and PA203.

**Florida Building Code Approval:** No. FL12672

**Standard Design Load:** 80 psf

**Maximum Design Load:** 150 psf

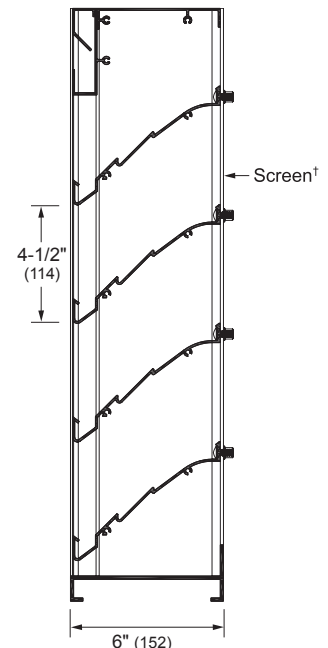
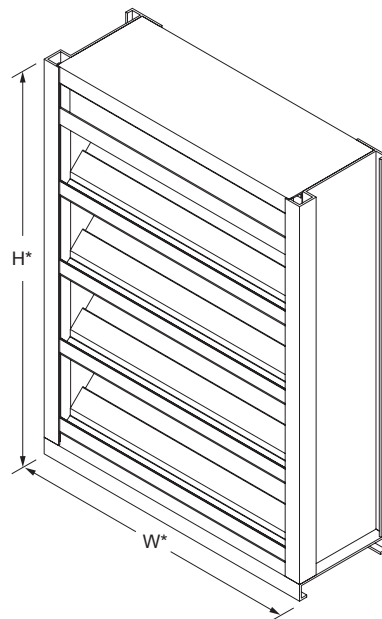

Model **EFD-637-MD**  
(standard)

\*Louver dimensions furnished  
approximately 1/2" (13) undersize.

**Vertical Section**

<sup>†</sup>Screen adds approximately  
3/16" (5) to louver depth.

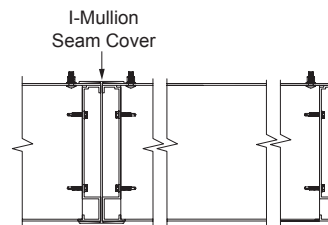

**Vertical Mullion**  
(standard)

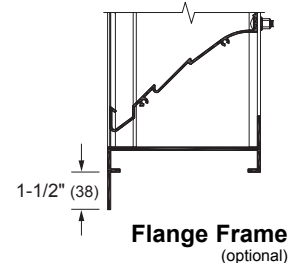

**Flange Frame**  
(optional)



### Certified Ratings:

All-Lite certifies that the model EFD-637-MD shown herein is licensed to bear the AMCA seal. The ratings shown are based on test and procedures performed in accordance with AMCA Publication 511 and comply with the requirements of the AMCA Certified Ratings Program. The AMCA Certified Ratings seal applies to air performance and water penetration ratings.

# Performance Data

## Free Area (ft<sup>2</sup>)

		Width (Inches)																						
		12	18	24	30	36	42	48	54	60	66	72	78	84	90	96	102	108	114	120	126	132	138	144
Height (Inches)	12	0.3	0.4	0.6	0.7	0.9	1.0	1.2	1.3	1.5	1.6	1.8	1.9	2.1	2.3	2.4	2.6	2.7	2.9	3.0	3.2	3.3	3.5	3.6
	18	0.6	0.9	1.2	1.6	1.9	2.2	2.6	2.9	3.2	3.6	3.9	4.2	4.6	4.9	5.2	5.6	5.9	6.2	6.6	6.9	7.2	7.6	7.9
	24	0.9	1.4	1.9	2.4	2.9	3.4	3.9	4.5	5.0	5.5	6.0	6.5	7.0	7.5	8.1	8.6	9.1	9.6	10.1	10.6	11.1	11.7	12.2
	30	1.2	1.9	2.5	3.2	3.9	4.6	5.3	6.0	6.7	7.4	8.1	8.8	9.5	10.2	10.9	11.6	12.3	13.0	13.7	14.4	15.1	15.7	16.4
	36	1.5	2.3	3.2	4.1	5.0	5.8	6.7	7.6	8.5	9.3	10.2	11.1	12.0	12.8	13.7	14.6	15.5	16.3	17.2	18.1	19.0	19.8	20.7
	42	1.8	2.8	3.9	4.9	6.0	7.0	8.1	9.1	10.2	11.3	12.3	13.4	14.4	15.5	16.5	17.6	18.6	19.7	20.8	21.8	22.9	23.9	25.0
	48	2.1	3.3	4.5	5.8	7.0	8.2	9.5	10.7	11.9	13.2	14.4	15.7	16.9	18.1	19.4	20.6	21.8	23.1	24.3	25.5	26.8	28.0	29.2
	54	2.4	3.8	5.2	6.6	8.0	9.4	10.9	12.3	13.7	15.1	16.5	17.9	19.4	20.8	22.2	23.6	25.0	26.4	27.8	29.3	30.7	32.1	33.5
	60	2.7	4.3	5.9	7.4	9.0	10.6	12.2	13.8	15.4	17.0	18.6	20.2	21.8	23.4	25.0	26.6	28.2	29.8	31.4	33.0	34.6	36.2	37.8
	66	3.0	4.7	6.5	8.3	10.1	11.8	13.6	15.4	17.2	19.0	20.7	22.5	24.3	26.1	27.8	29.6	31.4	33.2	34.9	36.7	38.5	40.3	42.0
	72	3.3	5.2	7.2	9.1	11.1	13.0	15.0	17.0	18.9	20.9	22.8	24.8	26.7	28.7	30.7	32.6	34.6	36.5	38.5	40.4	42.4	44.4	46.3
	78	3.6	5.7	7.8	10.0	12.1	14.2	16.4	18.5	20.7	22.8	24.9	27.1	29.2	31.3	33.5	35.6	37.8	39.9	42.0	44.2	46.3	48.4	50.6
	84	3.9	6.2	8.5	10.8	13.1	15.5	17.8	20.1	22.4	24.7	27.0	29.4	31.7	34.0	36.3	38.6	40.9	43.3	45.6	47.9	50.2	52.5	54.9
	90	4.2	6.7	9.2	11.7	14.2	16.7	19.2	21.6	24.1	26.6	29.1	31.6	34.1	36.6	39.1	41.6	44.1	46.6	49.1	51.6	54.1	56.6	59.1
96	4.5	7.1	9.8	12.5	15.2	17.9	20.5	23.2	25.9	28.6	31.2	33.9	36.6	39.3	42.0	44.6	47.3	50.0	52.7	55.4	58.0	60.7	63.4	
102	4.8	7.6	10.5	13.3	16.2	19.1	21.9	24.8	27.6	30.5	33.4	36.2	39.1	41.9	44.8	47.6	50.5	53.4	56.2	59.1	61.9	64.8	67.7	
108	5.1	8.1	11.1	14.2	17.2	20.3	23.3	26.3	29.4	32.4	35.5	38.5	41.5	44.6	47.6	50.7	53.7	56.7	59.8	62.8	65.8	68.9	71.9	
114	5.4	8.6	11.8	15.0	18.2	21.5	24.7	27.9	31.1	34.3	37.6	40.8	44.0	47.2	50.4	53.7	56.9	60.1	63.3	66.5	69.8	73.0	76.2	
120	5.7	9.1	12.5	15.9	19.3	22.7	26.1	29.5	32.9	36.3	39.7	43.1	46.5	49.9	53.3	56.7	60.1	63.5	66.9	70.3	73.7	77.1	80.5	
126	6.0	9.5	13.1	16.7	20.3	23.9	27.4	31.0	34.6	38.2	41.8	45.3	48.9	52.5	56.1	59.7	63.2	66.8	70.4	74.0	77.6	81.1	84.7	
132	6.3	10.0	13.8	17.5	21.3	25.1	28.8	32.6	36.4	40.1	43.9	47.6	51.4	55.2	58.9	62.7	66.4	70.2	74.0	77.7	81.5	85.2	89.0	
138	6.6	10.5	14.4	18.4	22.3	26.3	30.2	34.2	38.1	42.0	46.0	49.9	53.9	57.8	61.7	65.7	69.6	73.6	77.5	81.4	85.4	89.3	93.3	
144	6.9	11.0	15.1	19.2	23.4	27.5	31.6	35.7	39.8	44.0	48.1	52.2	56.3	60.4	64.6	68.7	72.8	76.9	81.0	85.2	89.3	93.4	97.5	



**Certified Ratings:**  
All-Lite certifies that the model EFD-637-MD shown herein is licensed to bear the AMCA seal. The ratings shown are based on test and procedures performed in accordance with AMCA Publication 511 and comply with the requirements of the AMCA Certified Ratings Program. The AMCA Certified Ratings seal applies to air performance, and water penetration ratings.

## Pressure Loss

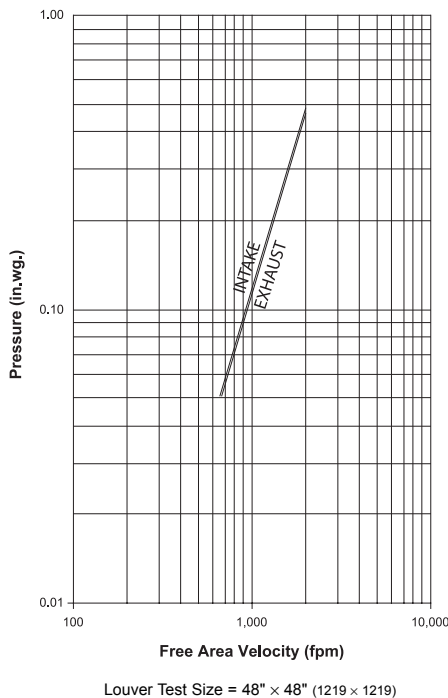

## Selection Criteria

Follow the steps listed below to calculate the louver size needed to satisfy the required air volume while minimizing the adverse effects of water penetration and pressure loss.

- Determine the Free Area Velocity (FAV) at the maximum allowable pressure loss using the *Pressure Loss* chart to the left. While job conditions vary, typically, the maximum allowable pressure loss should not exceed 0.15 in.wg., and the FAV for the 0.15 in.wg. pressure loss is listed on the front page of this sheet.
- Intake Applications** If the FAV at the Beginning Point of Water Penetration (shown below) is less than the FAV from step 1, then use the FAV at the Beginning Point of Water Penetration in step 3, otherwise use the FAV from step 1.

**Exhaust Applications** Use the FAV from step 1 in step 3.

- Calculate the total louver square footage required using the following equation.

$$\frac{\text{Required Air Volume (cfm)}}{\text{FAV (fpm)}} = \frac{\text{Required Louver (Free-Area) Size (ft}^2\text{)}}{\text{ft}^2}$$

- Using the *Free Area* chart above, select a louver width and height that yields a free area ft<sup>2</sup> greater than or equal to the required louver size calculated in step 3.

## Water Penetration

Beginning Point of Water Penetration = 990 fpm

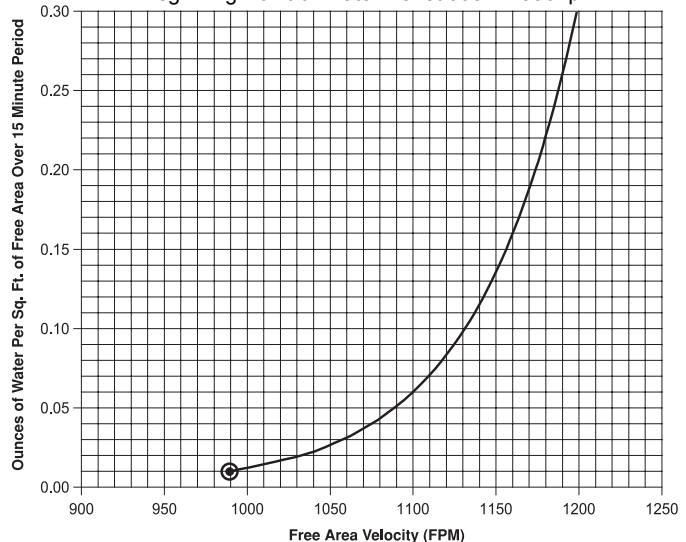

## Water Penetration

AMCA defines the beginning point of water penetration as the free area velocity at the intersection of a simple linear regression of test data and the line of 0.01 ounces of water per square foot of free area and is measured through a 48" x 48" louver during a 15 minute period. The AMCA water penetration test provides a method for comparing louver models and designs as to their efficiency in resisting the penetration of rainfall under specific lab conditions. All-Lite recommends that intake louvers are selected with a reasonable margin of safety below the beginning point of water penetration in order to avoid unwanted penetration during severe storm conditions.